

Review on Methods of Dynamic programming based Optimized controller for charging EV Batteries through Renewable Energies

MILAN CHOUBEY¹, Dr. MOHAN SEN², Dr. SEEMA SAXENA³

¹ School of Energy & environment management, UTD, RGPV Bhopal, Madhya Pradesh, India

² Department of Mechanical Engineering, DTE, Bhopal, Madhya Pradesh, India

³ Departments of Electrical Engineering, RGPV, Bhopal, Madhya Pradesh, India

ABSTRACT

The use of renewable energy and electric cars (EVs) can reduce the energy prices and minimize radiation to substantial extent. The intermittent nature of renewable energy sources and its sporadic use, integrating renewable energy sources into the electric grid is a challenging process. If the supply of renewable energy is not adequate to fulfill the requirement, it is expensive to pull more energy from the power grid. This may also reduce the energy efficiency of the charging process. Focus of this study is to present methods for optimizing a controller for the charging of electric vehicle batteries using renewable energy sources for energy management. Electrification of transportation, in particular, is viewed as one of the key avenues to achieving considerable CO₂ emission reductions. EVs have gained popularity in recent years, and more than 180 000 have been deployed worldwide too far. Even though this number represents just 0.02 per cent of all cars on the road, the International Energy Agency has set a lofty goal of having over 10 million electric buses and light duty vehicles (EV) on the road by 2030. The output of the Dynamic Programming optimization and a variety of other approaches used in energy optimizing software are compared to determine which one would accurately minimize the cost of energy required for charging and yet fulfill the aggregate battery charge maintaining criteria. Based on this study it is evident that the Dynamic Programming based optimization strategy provides the highest level of accuracy while maintaining a consistently high level of fuel savings in EVs.

KEYWORDS:

Electric Cars, Battery, Electric Vehicles, Dynamic Programming, Renewable Energy Sources;

1. Introduction

At the economic, environmental, industrial, and social levels, the lack of petroleum storage and the rise in gas emissions (CO₂, SO₂, and NO_x) have become global issues. Utilizing renewable energy sources to generate electricity has the potential to greatly decrease gas emissions and save the environment from future catastrophe [1]. Another viable alternative to save environment damage is to switch to EVs from conventional Internal Combustion Engine (ICE) vehicles. To avoid issues like high peaks and power losses for the grid and to reduce EV owners' charging expenses, coordinated charging is very important [2]. As renewable energy sources become more prevalent, traditional fossil fuel-based power-producing facilities are being phased out as the global energy landscape transforms [3]. Plug-in hybrid electric cars (PHEV) and Battery Electric Vehicles (BEV), which are becoming more prevalent, both contain sizable, supplied battery storage capacity that could be linked to the grid while parked for extended periods, creating new possibilities for the integration of Renewable energy sources (RES) [4]. Energy system optimizations are thought to have a significant influence on the numerous techno-economic studies about electric vehicle-to-grid integration since they disclose the ideal structure, characteristics, and management of an assessed, integrated energy system [5]. EVs may provide several advantages over

Conventional cars, like cheaper operating costs, reduced gas emissions, etc. EVs, on the other hand, provide a special energy storage capacity to support the production of renewable energy and the electrical grid [6]. EVs could be operated in a way that supports a rooftop Photovoltaic (PV) system, which can provide for the household's electrical needs while lowering costs [7]. Additionally, using renewable energy to charge EVs would gain popularity as a green and effective energy-use

strategy [8]. According to a study, charging 50,000 electric vehicles with renewable energy may cut annual gas emissions by 4×10^5 tons [9].

However, providing EV charging with renewable energy has its own set of issues. The intermittent nature of renewable energy generation, which is greatly impacted by weather, makes it difficult to plan and schedule the operation of power systems [10]. To lower the cost of obtaining additional energy and to improve power proficiency, it is crucial to carefully investigate the stochastic features and the dynamic support between renewable energy production and capacity requirement [11]. This study examines the most effective charging techniques based on dynamic programming to lower the overall cost of charging EVs. Figure 1 shows the schematic diagram of Electric Vehicle [12].

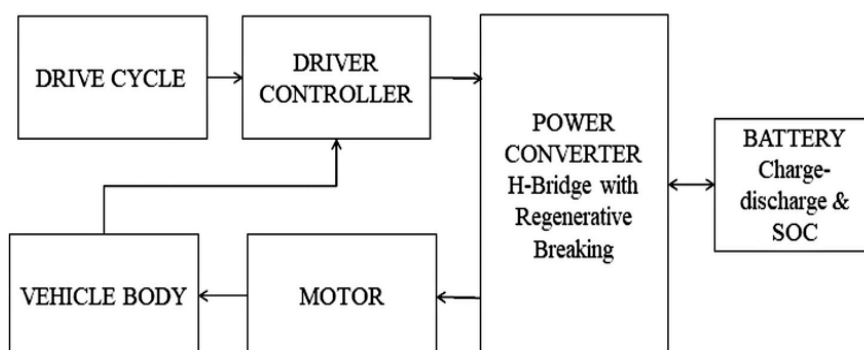

Figure 1: Block diagram of electric vehicle modeling

Electric Vehicle

An electric vehicle is a car, truck, or another motor vehicle that is propelled solely or mostly by one or more Electric Vehicles (EVs) [13]. It might be powered by a battery, a collecting system, or energy from extravehicular sources [14]. However, these methods cannot be utilized simultaneously. An EV is propelled by an electric motor as opposed to an internal combustion engine, which generates power by burning a combination of fuel and gases [15]. A few examples of electric vehicles are electric watercraft for both the surface and the depths of the sea, electric airplanes, and electric spaceships EVs [16]. Three primary categories of electric vehicles are plug-in hybrid electric vehicles (PHEV), hybrid electric vehicles (HEV), and Battery Electronic Vehicle (BEV) [17].

HEV (Hybrid Electric Vehicles)

Hybrid Electric Vehicles (HEV) combines an Internal Combustion Engine (ICE) with a battery pack and electric motor to reduce fuel consumption [18]. HEVs do this by applying an electric motor to propel the vehicle when ICE would be particularly wasteful, such as while accelerating from a standstill [19]. Hybrids could prefer the internal combustion engine (ICE) even if it would be more efficient for them not to do so in certain situations, such as while driving at highway speeds [20]. Figure 2 shows the schematic diagram of Hybrid Electric Vehicle [19].

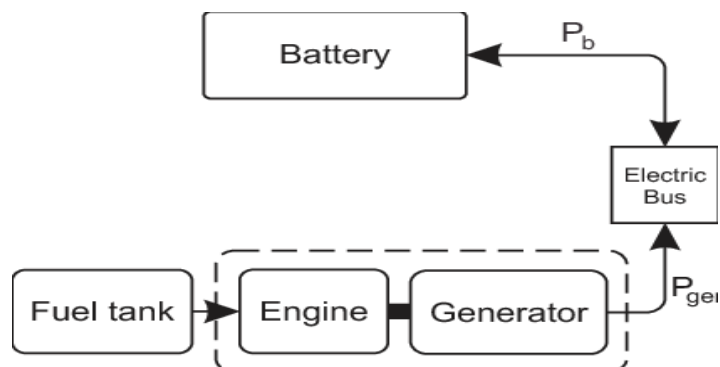

Figure 2: Schematic diagram of a HEV

PHEV (Plug-in Hybrid Electric Vehicles)

Plug-in Hybrid Electric Vehicles (PHEV) are a dual-fuel technology that aims to replace non-renewable, high-carbon fuels in the transportation energy infrastructure with more environmentally friendly options [21]. Electricity is one of the fuels used in PHEVs. PHEVs can give execution on par with that of today's cutting-edge automobiles [22]. Benefits are the consequence of switching from traditional transportation fuels to electricity, which is more significant, as well as an efficient fuel-energy distribution from the tank to the wheels [23]. Figure-3 shows the schematic diagram of Plug-in Hybrid Electric Vehicle [19].

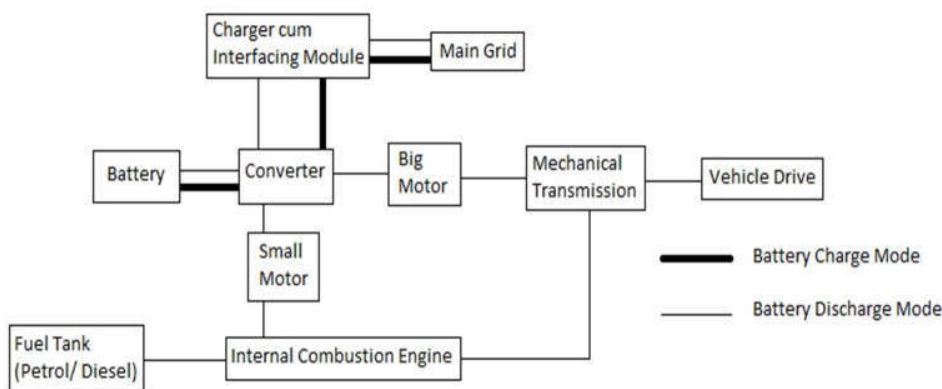

Figure 3: Schematic diagram of a PHEV

BEV (Battery Electric Vehicles)

Battery Electric Vehicles are known as pure electric vehicle, only electric vehicle, or fully electric vehicle refers to an EV that solely relies on chemical force accumulated in rechargeable battery sets and does not use any additional sources of power [24]. An "all-electric" or "full-electric" automobile is referred to as a BEV [25]. BEVs only use electricity, with onboard battery packs serving as a source of current for the electric motors in each vehicle [26]. BEVs lack all ICE components. Due to their exclusive dependence on electricity, BEVs often have batteries with much higher capacities and kilowatt-hour (kWh) outputs than equivalent hybrid and plug-in electric automobiles [27]. Because BEVs utilize more advanced batteries than other EV types, they are often more expensive [28]. One may get many of the benefits of a BEV while avoiding a number of its drawbacks by combining elements of BEVs with standard HEVs [29]. The PHEV has a lower cost penalty than a BEV with similar performance since it uses fewer batteries than a complete BEV [30]. Figure 4 shows the schematic diagram of Battery Electric Vehicle [31].

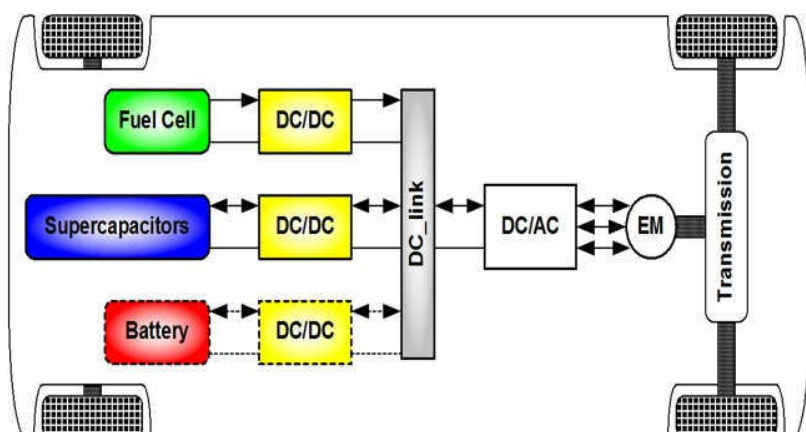

Figure 4: Schematic diagram of the battery electric vehicle

2. Dynamic Programming Method

To effectively solve a class of issues with overlapping sub problems and an optimum substructure property, dynamic programming combines mathematical optimization techniques with computer programming techniques [32]. Dynamic programming is a mathematical approach that may be used to solve any issue that calls for assessments to be done sequentially to find a decision route that incurs the least amount of penalty [33]. In the context of this discussion, a "penalty" is a numerical representation of the undesirable consequences that are caused by a decision [34]. The algorithm advances from the end of one duty cycle to the beginning of the next while it simultaneously calculating the penalty caused by different control settings at each time step [35]. The dynamic programming approach cannot be used in practical control methods because it requires prior knowledge of the duty cycle [36]. However, real controllers may be designed and tuned using the dynamic programming algorithm's outputs [37]. The benefits of DP optimization approaches are as follows:

- A decrease of about 40 percent in the cost of charging energy in the case when there is a low penetration of Renewable energy sources (RES) and a two-tariff electrical energy pricing pattern [38].
- Greater use of RES capability and, should it occur, a proportionately reduced cost of grid electricity for charging when RES share exceeds local energy demand without EVs [39].

The penalty function that was employed in this research assigned a penalty for the consumption of fuel, for failing to fulfill the duty cycle speed-time trace that was given, and for failing to maintain an end state of charge that was fair [40]. Only a small portion of the whole design space is investigated by the dynamic programming approach in its current form, which was employed for this study [41]. Because of this, the author could not say that the control is optimal, but rather that it is near-optimal [42]. A sort of global optimization approach known as dynamic programming, or simply DP, achieves its purpose by breaking a problem down into several step-based nuzzled sub problems, merging the results found at every level, and moving in reverse from the most recent stage to the one before it [43]. Following the optimality principle, the optimal outcomes are determined at each stage by computing them based on the ideal outcomes of the stage that came before [44]. The cost of charging customers is the primary emphasis of optimization, with consideration given to pricing changes [45]. Figure 5 depicts the flowchart of Dynamic Programming approach [46].

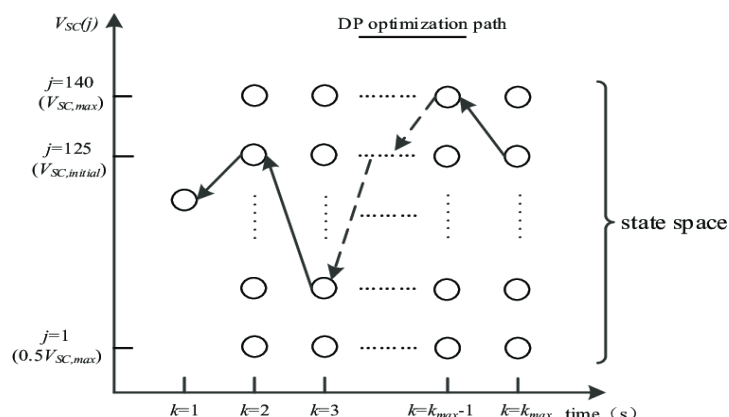

Figure 5: Dynamic programming (DP) approach flowchart

Renewable energy

One of the most potentially game-changing effects that EVs might have on the electrical system is their capacity to facilitate the incorporation of renewable power supplies into the current energy framework [47]. Coordinating EV charging with other grid demand and renewable production becomes exceedingly difficult due to RESs' intermittent and indispatchable nature [48]. The EV's unpredictable arrival, intermittent renewable energy, and fluctuating grid power prices are all considered and characterized as separate Markov processes [49]. The energy needed to charge each EV, meanwhile, varies randomly [50]. Plug-in electric vehicle adoption and the widespread use of renewable energy (RE) may both contribute to the decarbonization of the transportation and power sectors [51]. The station comprises renewable generating (wind and solar) and a storage system in order to increase the fast-charging stations' profitability and lower the high energy demand from the grid [52]. The transition to a low-carbon, highly integrated renewable society demands initiatives from a variety of sectors and levels [53]. A number of difficulties are noted, mostly as a result of the relevant population growth, the depletion of fossil fuel sources, a lack of energy security, and the expansion of the economy and urbanization [54]. With the aid of FEVs, the rising greenhouse gas emissions may be decreased [55]. The variable output power that is produced by renewable energy sources will be stored in a storage system [56]. A fixed-point digital signal processor applies a power factor correction technique for an inbuilt battery charger for traction propulsion [57]. The battery management system turns on the battery packs' voltage- or current-controlled charging modes [58]. Due to environmental concerns, hybrid power production that is based on renewable energy (RE) has gained popularity [59]. The RE-based power production may be utilized to meet local loads in distant locations without a grid connection and with less transmission loss [60]. In comparison to fossil fuels, wind power producing systems have less of a negative influence [61]. Figure 6 describes the basic representation of Solar Vehicle.

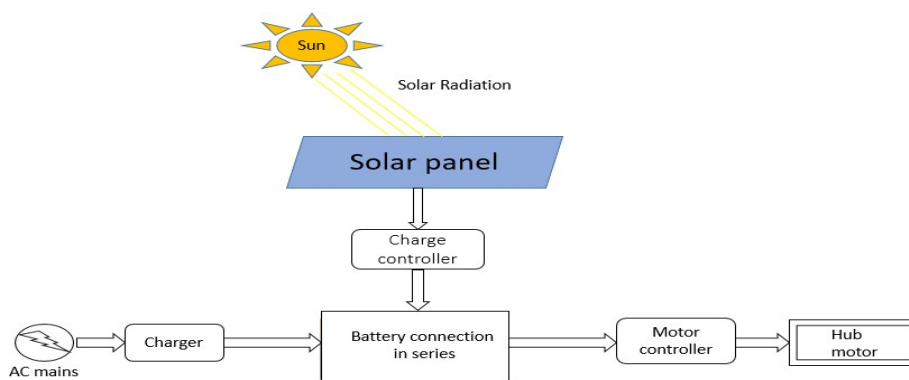

Figure 6: Block Diagram Representation of Solar vehicle

Wind energy

A sixteen-fold expansion in northeastern wind power capability was predicted while modeling the Brazilian electrical sector from 2010 to 2030 [62]. The number of PHEVs (plug-in hybrid electric vehicles) whose batteries might be replenished by the excess wind power output is then calculated [63]. The excess production varies seasonally and happens more often between January and June; hence the authors accept that the automobiles operate on nearby manufactured ethanol during the other months of the year [64].

Solar energy

Combining immediate battery recharging from solar photo voltaic with the parking lot chargers that were discussed before is one way to make use of the benefits offered by this kind of charging [65]. Solar cars are not designed to be utilized for business reasons; however, the Vehicle-integrated Photovoltaics (VIPV) might be used to increase the fuel economy of hybrid and electric vehicles which are already on the road [66]. It is anticipated that this would result in a 10–20% increase in the fuel economy of the car [67].

3. Literature review

This part emphasizes various works on the topic of Dynamic programming based optimal controller for charging electric vehicle batteries using renewable energy. **Table 1** shows the summarized study of the various researchers engaged in the field.

Table 1 -Summarized study of the various researchers engaged in the field

Author	Technique	Outcome
Yang et al., (2021) [71]	Dynamic Programming (DP)	Compares the GA-centered charging program to the DP-centered charging program and the baseline charging plan, the overall charging cost is lowered by 41.5% and 46.3%, using the two alternative charging schedules.
Shibl et al., (2020) [74]	Machine Learning algorithms	The results are achieved by using the LSTM model comparing quadratic programming; however, the ML approach was much more time and effort efficient. LSTM was found to be the best model, with 95.3% accuracy and a 0.71% error rate; this model delivers the greatest results when attempting to forecast the power rating (PR) that is most suited for electric vehicle charging stations (EVCS).

Salazar et al., (2020) [73]	Stochastic optimization (stochastic DP formulation), time-variant Markov model.	The simulation results are provided to demonstrate how effective the suggested DP-based technique is in comparison to an algorithm that is based on rules.
Yu et al., (2019) [75]	Dynamic Programming	The findings demonstrate that owing to the nature of EV use, the mid-morning EV mandate for commercial fleets cannot be moved to another period.
Aragón et al., (2019) [76]	Stochastic Optimization Software Framework (SOFW) and dynamic programming	The findings demonstrate that the control that was put in place guaranteed that the local renewable energy source's power was fully used.
Joseph et al., (2018) [77]	Wireless charging topologies	Adopted a novel rectangular coil design in place of the standard circular core-winding pair, which yielded efficient charging system.
Škugor et al., (2015) [78]	Dynamic Programming	When extrapolated to cover longer periods, the results drawn from DP optimization established on the regular and the weakly intervals were too optimistic in their estimations of the charging cost.
Jin et al., (2014) [1]	Lyapunov optimization method	The results showed that the Lyapunov optimization-based EV charging scheduling method may reduce charging expenses as well as the average time needed to finish EV charging.
Chen et al., (2014) [79]	Dynamic Programming	The suggested technique may need less computing time in exchange for improved management of battery and fuel efficiency performance.

O'Keefe et al., (2006) [4]	A dynamic programming optimization approach	Under optimal conditions, the quantity of gasoline used by a strategy that utilizes mixed control and one that emphasizes the use of electric vehicles is same for a given set of objective distances.
-----------------------------------	---	--

4. Comparative Analysis

Predicting a Dynamic programming-based optimized controller for charging EV batteries in renewable energies has been a long-term objective of this study, which would explore previous studies done in this field. In comparison to other methods, the Dynamic Programming Optimization (DPO) approach has found to have the highest accuracy (91%). Machine Learning (ML) algorithms with 90.3 percent of accuracy and stochastic DP formulation (SDPF) with 88.52 percent accuracy come afterwards. Wireless Charging Topologies (WCT) performs with 88 percent accuracy and Lyapunov Optimization (LO) Method with 72.31 percent accuracy.

Table 2 shows the comparative study of various authors based on accuracy and used techniques.

Table 2: Comparative analysis

Author	Technique	Accuracy
Yang et al., (2021) [71]	Dynamic programming Optimization (DPO) Approach	91.0%
Shibl., et al (2020) [74]	Machine Learning (ML) algorithms	90.3%
Salazar et al., (2020) [73]	Stochastic Dynamic programming formulation (SDPF)	88.5%
Joseph et al., (2018) [77]	Wireless Charging Topologies (WCT)	88.0%
Jin et al., (2014) [1]	Lyapunov Optimization (LO) Method	72.3%

Figure 7 shows the comparison graph for the different technique's (Dynamic programming Optimization Approach, Machine Learning algorithm, Stochastic DP formulation, Wireless Charging Topologies, Lyapunov Optimization Method) accuracy in the existing literature.

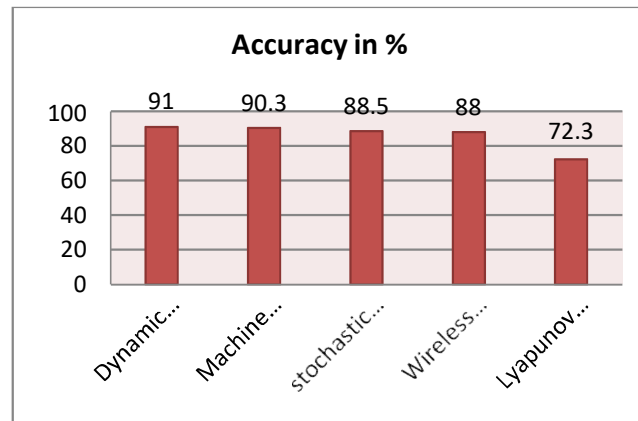

Figure 7: Comparison graph for the classifier's accuracy.

5. Conclusion

This comparison technique for optimizing the controller of charging the electric car batteries using renewable energy sources is proposed in this review study that was conducted with the goal of maximize the use of renewable energy. The Dynamic Programming Optimization (DPO) methodology offers the greatest accuracy of 91 percent when compared to other approaches to optimizing the charging of electric vehicle batteries using renewable energy. In addition, there is a discussion of the well-known methods that are available and these can be utilized to improve the process of charging the batteries of electric vehicles using renewable energy sources. This study's primary objective is to compile all of the pertinent information, such as previous research on Dynamic Programming, electric vehicle batteries, renewable energy batteries, and existing approaches, and provide the details in most comprehensive way.

References

- [1] Jin, Chenrui, Xiang Sheng, and Prasanta Ghosh. "Optimized electric vehicle charging with intermittent renewable energy sources." *IEEE Journal of Selected Topics in Signal Processing* 8, no. 6 (2014): 1063-1072.
- [2] Hafiz, Faeza, PoriaFajri, and Iqbal Husain. "Load regulation of a smart household with PV-storage and electric vehicle by dynamic programming successive algorithm technique." In 2016 IEEE Power and Energy Society General Meeting (PESGM), pp. 1-5. IEEE, 2016.
- [3] Zhu, Yuanheng, Dongbin Zhao, Xiangjun Li, and Ding Wang. "Control-limited adaptive dynamic programming for multi-battery energy storage systems." *IEEE Transactions on Smart Grid* 10, no. 4 (2018): 4235-4244.
- [4] O'Keefe, Michael Patrick, and Tony Markel. *Dynamic programming applied to investigate energy management strategies for a plug-in HEV*. No. Conference Paper NREL/CP-540-40376. Golden, Colorado, USA: National Renewable Energy Laboratory, 2006.
- [5] Korkas, Christos D., Simone Baldi, Shuai Yuan, and Elias B. Kosmatopoulos. "An adaptive learning-based approach for nearly optimal dynamic charging of electric vehicle fleets." *IEEE Transactions on Intelligent Transportation Systems* 19, no. 7 (2017): 2066-2075.
- [6] Wu, Xiaohua, Xiaosong Hu, Scott Moura, Xiaofeng Yin, and Volker Pickert. "Stochastic control of smart home energy management with plug-in electric vehicle battery energy storage and photovoltaic array." *Journal of Power Sources* 333 (2016): 203-212.
- [7] Tischer, Henning, and Gregor Verbic. "Towards a smart home energy management system-a dynamic programming approach." In 2011 IEEE PES Innovative Smart Grid Technologies, pp. 1-7. IEEE, 2011.
- [8] Cubito, Claudio, Luciano Rolando, Alessandro Ferraris, Massimiliana Carello, and Federico Millo. "Design of the control strategy for a range extended hybrid vehicle by means of dynamic programming optimization." In 2017 IEEE Intelligent Vehicles Symposium (IV), pp. 1234-1241. IEEE, 2017.
- [9] Richardson, David B. "Electric vehicles and the electric grid: A review of modeling approaches, Impacts, and renewable energy integration." *Renewable and Sustainable Energy Reviews* 19 (2013): 247-254.
- [10] Xie, Shengli, Weifeng Zhong, Kan Xie, Rong Yu, and Yan Zhang. "Fair energy scheduling for vehicle-to-grid networks using adaptive dynamic programming." *IEEE transactions on neural networks and learning systems* 27, no. 8 (2016): 1697-1707.
- [11] A. Y. Saber and G. K. Venayagamoorthy, Plug-in vehicles and renewable energy sources for cost and emission reductions, IEEE

- Transactions on Industrial Electronics, vol. 58, no. 4, 2011, pp. 186–193.
- [12] Shah, Rajnikant. "Modelling and performance analysis of electric vehicle." (2021).
- [13] Chan, C. C. "An overview of electric vehicle technology." *Proceedings of the IEEE* 81, no. 9 (1993): 1202-1213.
- [14] Yong, Jia Ying, Vigna K. Ramachandaramurthy, Kang Miao Tan, and Nadarajah Mithulananthan. "A review on the state-of-the-art technologies of electric vehicle, its impacts and prospects." *Renewable and sustainable energy reviews* 49 (2015): 365-385.
- [15] Tran, Martino, David Banister, Justin DK Bishop, and Malcolm D. McCulloch. "Realizing the electric-vehicle revolution." *Nature climate change* 2, no. 5 (2012): 328-333.
- [16] Situ, Lixin. "Electric vehicle development: the past, present & future." In *2009 3rd International Conference on Power Electronics Systems and Applications (PESA)*, pp. 1-3. IEEE, 2009.
- [17] Ding, Ning, Krishnamachar Prasad, and Tek Tjing Lie. "The electric vehicle: a review." *International Journal of Electric and Hybrid Vehicles* 9, no. 1 (2017): 49-66.
- [18] Butler, Karen L., Mehrdad Ehsani, and Preyas Kamath. "A Matlab-based modeling and simulation package for electric and hybrid electric vehicle design." *IEEE Transactions on vehicular technology* 48, no. 6 (1999): 1770-1778.
- [19] Musardo, Cristian, Giorgio Rizzoni, Yann Guezennec, and Benedetto Staccia. "A-ECMS: An adaptive algorithm for hybrid electric vehicle energy management." *European journal of control* 11, no. 4-5 (2005): 509-524.
- [20] Moreno, Jorge, Micah E. Ortúzar, and Juan W. Dixon. "Energy-management system for a hybrid electric vehicle, using ultracapacitors and neural networks." *IEEE transactions on Industrial Electronics* 53, no. 2 (2006): 614-623.
- [21] Emadi, Ali, Young Joo Lee, and Kaushik Rajashekara. "Power electronics and motor drives in electric, hybrid electric, and plug-in hybrid electric vehicles." *IEEE Transactions on industrial electronics* 55, no. 6 (2008): 2237-2245.
- [22] Amjad, Shaik, S. Neelakrishnan, and R. Rudramoorthy. "Review of design considerations and technological challenges for successful development and deployment of plug-in hybrid electric vehicles." *Renewable and Sustainable Energy Reviews* 14, no. 3 (2010): 1104-1110.
- [23] Clement-Nyns, Kristien, Edwin Haesen, and Johan Driesen. "The impact of charging plug-in hybrid electric vehicles on a residential distribution grid." *IEEE Transactions on power systems* 25, no. 1 (2009): 371-380.
- [24] Cuma, Mehmet Ugras, and Tahsin Koroglu. "A comprehensive review on estimation strategies used in hybrid and battery electric vehicles." *Renewable and Sustainable Energy Reviews* 42 (2015): 517-531.
- [25] Thomas, C. E. "Fuel cell and battery electric vehicles compared." *international journal of hydrogen energy* 34, no. 15 (2009): 6005-6020.
- [26] Li, Wenbo, Ruyin Long, Hong Chen, and Jichao Geng. "A review of factors influencing consumer intentions to adopt battery electric vehicles." *Renewable and Sustainable Energy Reviews* 78 (2017): 318-328.
- [27] König, Adrian, Lorenzo Nicoletti, Daniel Schröder, Sebastian Wolff, Adam Waclaw, and Markus Lienkamp. "An overview of parameter and cost for battery electric vehicles." *World Electric Vehicle Journal* 12, no. 1 (2021): 21.
- [28] Ma, Hongrui, Felix Balthasar, Nigel Tait, Xavier Riera-Palou, and Andrew Harrison. "A new comparison between the life cycle greenhouse gas emissions of battery electric vehicles and internal combustion vehicles." *Energy policy* 44 (2012): 160-173.
- [29] Eaves, Stephen, and James Eaves. "A cost comparison of fuel-cell and battery electric vehicles." *Journal of Power Sources* 130, no. 1-2 (2004): 208-212.
- [30] Safari, Mohammadhosein. "Battery electric vehicles: Looking behind to move forward." *Energy Policy* 115 (2018): 54-65.
- [31] Makrygiorgou, Jemma J., and Antonio T. Alexandridis. "Dynamic analysis of induction machine driven electric vehicles based on the nonlinear accurate model." In *2016 24th Mediterranean Conference on Control and Automation (MED)*, pp. 479-484. IEEE, 2016.
- [32] Bellman, Richard E., and Stuart E. Dreyfus. *Applied dynamic programming*. Vol. 2050. Princeton university press, 2015.
- [33] Bertsekas, Dimitri P., *Dynamic Programming and Optimal Control*, Athens Scientific, 2000.
- [34] Eddy, Sean R. "What is dynamic programming?" *Nature biotechnology* 22, no. 7 (2004): 909-910.
- [35] Bellman, Richard. "The theory of dynamic programming." *Bulletin of the American Mathematical Society* 60, no. 6 (1954): 503-515.
- [36] Sniedovich, Moshe. *Dynamic programming*. Vol. 297. CRC press, 1991.
- [37] Ross, Sheldon M. *Introduction to stochastic dynamic programming*. Academic press, 2014.
- [38] Howard, Ronald A. "Dynamic programming." *Management Science* 12, no. 5 (1966): 317-348.
- [39] Yakowitz, Sidney. "Dynamic programming applications in water resources." *Water resources research* 18, no. 4 (1982): 673-696.
- [40] Bellman, Richard. "On the theory of dynamic programming." *Proceedings of the national Academy of Sciences* 38, no. 8 (1952): 716-719.
- [41] Rust, John. "Dynamic programming." *The new Palgrave dictionary of economics* 1 (2008): 8.
- [42] Denardo, Eric V. *Dynamic programming: models and applications*. Courier Corporation, 2012.
- [43] Blackwell, David. "Discrete dynamic programming." *The Annals of Mathematical Statistics* (1962): 719-726.
- [44] Iyengar, Garud N. "Robust dynamic programming." *Mathematics of Operations Research* 30, no. 2 (2005): 257-280.
- [45] Bertsekas, Dimitri P. "Approximate dynamic programming." (2008).

- [46] Pan, Chaofeng, Yanyan Liang, Long Chen, and Liao Chen. "Optimal control for hybrid energy storage electric vehicle to achieve energy saving using dynamic programming approach." *Energies* 12, no. 4 (2019): 588.
- [47] Mwasilu, Francis, Jackson John Justo, Eun-Kyung Kim, Ton Duc Do, and Jin-Woo Jung. "Electric vehicles and smart grid interaction: A review on vehicle to grid and renewable energy sources integration." *Renewable and sustainable energy reviews* 34 (2014): 501-516.
- [48] Liu, Liansheng, Fanxin Kong, Xue Liu, Yu Peng, and Qinglong Wang. "A review on electric vehicles interacting with renewable energy in smart grid." *Renewable and Sustainable Energy Reviews* 51 (2015): 648-661.
- [49] Szinai, Julia K., Colin JR Sheppard, Nikit Abhyankar, and Anand R. Gopal. "Reduced grid operating costs and renewable energy curtailment with electric vehicle charge management." *Energy Policy* 136 (2020): 111051.
- [50] Domínguez-Navarro, J. A., R. Dufo-López, J. M. Yusta-Loyo, J. S. Artal-Sevil, and J. L. Bernal-Agustín. "Design of an electric vehicle fast-charging station with integration of renewable energy and storage systems." *International Journal of Electrical Power & Energy Systems* 105 (2019): 46-58.
- [51] Andersen, Poul H., John A. Mathews, and Morten Rask. "Integrating private transport into renewable energy policy: The strategy of creating intelligent recharging grids for electric vehicles." *Energy policy* 37, no. 7 (2009): 2481-2486.
- [52] Gil-García, Isabel C., M^a Socorro García-Cascales, Habib Dagher, and Angel Molina-García. "Electric vehicle and renewable energy sources: Motor fusion in the energy transition from a multi-indicator perspective." *Sustainability* 13, no. 6 (2021): 3430.
- [53] Wang, Ran, Ping Wang, and Gaoxi Xiao. "Two-stage mechanism for massive electric vehicle charging involving renewable energy." *IEEE Transactions on Vehicular Technology* 65, no. 6 (2016): 4159-4171.
- [54] Nienhueser, Ian Andrew, and Yueming Qiu. "Economic and environmental impacts of providing renewable energy for electric vehicle charging—A choice experiment study." *Applied energy* 180 (2016): 256-268.
- [55] Chellaswamy, C., L. Balaji, and T. Kaliraja. "Renewable energy based automatic recharging mechanism for full electric vehicle." *Engineering Science and Technology, an International Journal* 23, no. 3 (2020): 555-564.
- [56] Fathabadi, Hassan. "Utilization of electric vehicles and renewable energy sources used as distributed generators for improving characteristics of electric power distribution systems." *Energy* 90 (2015): 1100-1110.
- [57] Schuller, Alexander, Christoph M. Flath, and Sebastian Gottwalt. "Quantifying load flexibility of electric vehicles for renewable energy integration." *Applied Energy* 151 (2015): 335-344.
- [58] Lopes, João Peças, Pedro Miguel Rocha Almeida, Antero Miguel Silva, and Filipe Joel Soares. "Smart charging strategies for electric vehicles: Enhancing grid performance and maximizing the use of variable renewable energy resources." (2009).
- [59] Quddus, Md Abdul, Mohannad Kabli, and Mohammad Marufuzzaman. "Modeling electric vehicle charging station expansion with an integration of renewable energy and Vehicle-to-Grid sources." *Transportation Research Part E: Logistics and Transportation Review* 128 (2019): 251-279.
- [60] Peters, Annemijn Maron, Ellen van der Werff, and Linda Steg. "Beyond purchasing: Electric vehicle adoption motivation and consistent sustainable energy behaviour in The Netherlands." *Energy Research & Social Science* 39 (2018): 234-247.
- [61] Alkaws, Gamal, Yahia Baashar, Dallatu Abbas U, Ammar Ahmed Alkahtani, and Sieh Kiong Tiong. "Review of renewable energy-based charging infrastructure for electric vehicles." *Applied Sciences* 11, no. 9 (2021): 3847.
- [62] Borba B, Szklo A, Schaeffer R. Plug-in hybrid electric vehicles as a way to maximize the integration of variable renewable energy in power systems: the case of wind generation in northeastern Brazil. *Energy* 2012;37:469–81.
- [63] Colmenar-Santos, Antonio, Antonio-Miguel Muñoz-Gómez, Enrique Rosales-Asensio, and África López-Rey. "Electric vehicle charging strategy to support renewable energy sources in Europe 2050 low-carbon scenario." *Energy* 183 (2019): 61-74.
- [64] Seddig, Katrin, Patrick Jochem, and Wolf Fichtner. "Integrating renewable energy sources by electric vehicle fleets under uncertainty." *Energy* 141 (2017): 2145-2153.
- [65] Chowdhury, Nusrat, Chowdhury Akram Hossain, Michela Longo, and Wahiba Yaïci. "Optimization of solar energy system for the electric vehicle at university campus in Dhaka, Bangladesh." *Energies* 11, no. 9 (2018): 2433.
- [66] Letendre S. Vehicle integrated photovoltaics: exploring the potential. In: *Proceedings of the 23rd annual electric vehicles symposium*. Anaheim, CA; 2007.
- [67] Araki, Kenji, Liang Ji, George Kelly, and Masafumi Yamaguchi. "To do list for research and development and international standardization to achieve the goal of running a majority of electric vehicles on solar energy." *Coatings* 8, no. 7 (2018): 251.
- [68] Shafie-Khah, M., Nilufar Neyestani, M. Y. Damavandi, F. A. S. Gil, and J. P. S. Catalão. "Economic and technical aspects of plug-in electric vehicles in electricity markets." *Renewable and Sustainable Energy Reviews* 53 (2016): 1168-1177.
- [69] Bartolozzi, I., F. Rizzi, and Marco Frey. "Comparison between hydrogen and electric vehicles by life cycle assessment: A case study in Tuscany, Italy." *Applied energy* 101 (2013): 103-111.
- [70] Karmaker, Ashish Kumar, Md Raju Ahmed, Md Alamgir Hossain, and Md Mamun Sikder. "Feasibility assessment & design of hybrid renewable energy based electric vehicle charging station in Bangladesh." *Sustainable cities and society* 39 (2018): 189-202.
- [71] Yang, Kuo, and Ping Chen. "Optimization of Charging Schedule for Battery Electric Vehicles Using DC Fast Charging Stations."

- IFAC-PapersOnLine 54, no. 20 (2021): 418-423.
- [72] Salazar, Andres, Alberto Berzoy, Wenzhan Song, and Javad MohammadpourVelni. "Energy management of islanded nanogrids through nonlinear optimization using stochastic dynamic programming." *IEEE Transactions on Industry Applications* 56, no. 3 (2020): 2129-2137.
- [73] Shibl, Mostafa, Loay Ismail, and Ahmed Massoud. "Machine learning-based management of electric vehicles charging: Towards highly-dispersed fast chargers." *Energies* 13, no. 20 (2020): 5429.
- [74] Yu, Danilo, Min Prasad Adhikari, AurelienGuiral, Alan S. Fung, Farahnaz Mohammadi, and KaamranRaahemifar. "The impact of charging battery electric vehicles on the load profile in the presence of renewable energy." In *2019 IEEE Canadian Conference of Electrical and Computer Engineering (CCECE)*, pp. 1-4. IEEE, 2019.
- [75] Aragón, Gustavo, ErdemGümrükcü, Vinoth Pandian, and Otilia Werner-Kytölä. "Cooperative control of charging stations for an EV park with stochastic dynamic programming." In *IECON 2019-45th Annual Conference of the IEEE Industrial Electronics Society*, vol. 1, pp. 6649-6654. IEEE, 2019.
- [76] Joseph, Peter K., and D. Elangovan. "A review on renewable energy powered wireless power transmission techniques for light electric vehicle charging applications." *Journal of Energy Storage* 16 (2018): 145-155.
- [77] Škugor, Branimir, and JoškoDeur. "Dynamic programming-based optimisation of charging an electric vehicle fleet system represented by an aggregate battery model." *Energy* 92 (2015): 456-465.
- [78] Chen, Bo-Chiuan, Yuh-Yih Wu, and Hsien-Chi Tsai. "Design and analysis of power management strategy for range extended electric vehicle using dynamic programming." *Applied Energy* 113 (2014): 1764-1774.
- [79] Neupane, Sudan. "Design modification and performance testing of solar assistive electric vehicle." *Journal of Innovations in Engineering Education* 4, no. 1 (2021): 83-86.